

Skunkworks Robotics Safety and Health Plan 2011-2012



Aviation High School Team 1983



<http://ahsrobotics.us/home/index.html>

Prepared By:
Hunter McSwain



Mentors:
Steve Tarilton

Table of Contents

1.0 Introduction

1.1 Purpose

1.2 Scope

1.3 Four Elements of the Shop Safety Health Plan (SSHP)

1.4 Key Components of Each Element

1.4.1 Coach/Mentors Commitment and Team Involvement

1.4.2 Team Safety Analysis

1.4.3 Hazard Prevention and Control

1.4.4 Training and Education

2.0 Coach/Mentors Commitment and Team Involvement

2.1 Coach Policy Statements on Safety and Health

2.2 Responsibilities

2.2.1 Coach Responsibilities

2.2.2 Team Safety Captain Responsibilities

2.2.3 Team Responsibilities

2.3 Resources to Maintain Safety and Health Program

2.4 Safety Committee

2.4.1 Safety and Committee Members

2.4.2 Responsibilities

2.4.3 Safety Meetings

2.5 Disciplinary actions for safety and health infractions

2.5.1 Verbal Warning infractions

2.5.2 Team Member Removal

3.0 Team Safety Analysis

3.1 On-site inspection of shop area

3.1.1 Job Safety Analysis Form for Shop

3.1.2 Deficiencies Found

3.1.3 Audits by Mentors

3.2 Competition

3.2.1 Team Travel Safety Protocol

3.3 Accident/incident investigation

3.3.1 Coach's Action

3.3.2 The Safety Committee's Action

3.3.3 Incident Investigation Procedure

4.0 Hazard Prevention and Control

4.1 General Safety Rules

4.1.1 Basic Safety Rules

4.1.2 Basic Machine Shop Safety Rules

4.2 Required Personal Protective Equipment (PPE) for Machine Shop

4.2.1 Safety Glasses

4.2.2 Hearing Protection

4.2.3 Foot protection

4.2.4 Hand protection

4.3 Job Related Safety Rules

4.3.1 Work in or passing through the Machine shop

4.3.2 Work with grinders: Machine shop

4.3.3 Work with Miter Saws: Machine shop

4.3.4 Work with Band Saw: Machine Shop

4.3.5 Work with Table Saw: Machine shop

4.3.6 Work with Belt Sander: Machine shop

4.3.7 Work with Drill Press: Machine shop

4.3.8 Work with Lathe: Machine shop

4.3.9 Work with Milling Machine: Machine shop

4.3.10 Work with hand tools

4.3.11 Work with power hand tools

4.4 Chemical Safety

4.4.1 Work Rules

4.4.2 Required PPE

4.5 Competition Safety Rules

4.5.1 Required PPE

4.5.2 Work Rules

4.6 Emergency Planning

4.6.1 In Case of Fire

4.6.2 In Case of Earthquake

5.0 Safety and Health Training and Education

5.1 General Safety Training

5.1.1 Basic Safety Orientation Training

5.1.2 Competition Safety Orientation Training

5.1.3 Travel Orientation Training

5.2 Personal Protective Equipment Training

5.2.1 Eye Protection Training

5.2.2 Hearing Protection Training

5.2.3 Hand Protection Training

5.3 Structured Specific Safety Training

5.3.1 Machine Shop Safety Training

5.3.2 Chemical Safety Training Overview

6.0 Appendices

6.1 Appendix A

6.2 Appendix B

6.3 Appendix C

1.0 Introduction

The Skunkworks Safety and Health Program (SSHP) contains four elements. We find that all parts in their entirety are essential. It is understood that this program is to be followed completely.

This program was originally prepared during the team's rookie year in 2007, and has been updated annually for clarity and the understanding of the Skunkworks Safety Captain and the Skunkworks team. The original program was reviewed by Venetia A. Runnion, Certified Industrial Hygienist (CIH) and Certified Safety Professional (CSP). This program has been instituted by Coach Robert Steele, and embraced by the entire Skunkworks team. The student safety captain for the 2012 season is Hunter McSwain.

1.1 Purpose

This safety program is an easy to use guide for important safety and health information for Coach/Mentors and team members.

1.2 Scope

This program applies to Coach/Mentors and team members of the FIRST Team 1983 Skunkworks Robotics.

1.3 Four Elements of the SSHP

1. Coach/Mentor Commitment and Team Involvement
2. Shop and Pit Job Safety Analysis
3. Hazard Prevention and Control
4. Training and Education

1.4 Key Components of Each Element

1.4.1 Coach/Mentors Commitment and Team Involvement

1. Coach policy statement on safety and health
2. Coach, Team Safety Captain, and Team responsibilities
3. Provisions for resources to maintain a safety and health program
4. Team participation in safety committees
5. Disciplinary actions for safety and health infractions

1.4.2 Team Safety Analysis

1. On-site inspection of shop and pit areas (competitions)
2. Audits by mentors

1.4.3 Hazard Prevention and Control

1. Procedures and policies on health and safety
2. Personal protective equipment (PPE)
3. Reliance on For Inspiration and Recognition of Science and Technology (FIRST) Robotics Competition Team Safety Manual

1.4.4 Training and Education

1. Training sessions required by law
2. General training sessions

2.0 Coach/Mentors Commitment and Team Involvement

A successful safety and health program is only as good as the Coach's commitment and the team's involvement. The key to success is active involvement with proactive communication.

2.1 Coach Policy Statement on Safety and Health

It is the policy of the Skunkworks Robotics Team to pursue every reasonable effort to provide a safe and healthy working environment for mentors and team members. The Coach expects each team member to conduct their work and activities in a safe manner. The safety and health of our team members and mentors is our highest priority. Mentors and team members alike are required to follow all Aviation High School and Skunkworks safety rules. Unsafe working conditions, unsafe practices, or machines that are unsafe to operate must be reported to Coach, Safety Mentor, or Student Safety Captain (all considered Safety Team Leaders) immediately. Mentors or Team Members also must report to the Safety Team Leaders any injuries that occur as part of the design, construction, travel and competition events for the Skunkworks Robotics Team.

Also, as part of gracious professionalism advocated by *FIRST* we shall mentor and support other Robotics Team in safety and health issues. This will be accomplished either directly, such as during competitions providing input in pit operations, or indirectly, such as how we mentor new teams in our locale.

2.2 Responsibilities

Everyone is responsible for safety during design, construction, travel and competition events (the "season") for the Skunkworks Robotics Team. This includes reading and understanding this program as well as one's participation and comprehension in training. Each team member is responsible for communicating effectively in order to meet the overall goal of providing the safest environment.

2.2.1 Coach Responsibilities

1. Ensure that a team safety committee is formed and is carrying out its responsibilities as described in this program.
2. Evaluate the Safety Captain's performance each year to make sure they are carrying out their responsibilities as described in this program.
3. Ensure that incidents are fully investigated and corrective action is taken to prevent the hazardous conditions or behaviors from happening again.
4. Ensure that a record of injuries and/or illnesses is maintained and posted as described in this program.
5. Set a good example by following established safety rules and attending required training.

2.2.2 Team Safety Captain Responsibilities

1. Ensure that each team member has received an initial orientation before beginning the season.
2. Guarantee that each team member receives shop safety training pertaining to the safety expectations for tools before starting work on that equipment or project.
3. Confirm that each team member receives required personal protective equipment (PPE) before starting work on a project requiring PPE.
4. Do a daily walk-around safety-check of the work area. Promptly correct any hazards you find.
5. Set a good example for team members by following safety rules and present shop safety presentation as well as give shop safety expectations.
6. Report all incidents to the Coach.
7. Talk to Coach about changes to work practices or equipment that will improve team safety.

2.2.3 Team Responsibilities

1. Follow safety rules described in this program and in any training that you receive.
2. Report unsafe conditions or actions to the safety committee representative promptly.
3. Notify all injuries to Coach promptly regardless of how serious.
4. Report all near-miss incidents to safety committee representative promptly.
5. Always use personal protective equipment (PPE) in good working condition where it is required.
6. Do not remove or break any safety device or safeguard provided for team member protection.
7. Encourage team members to use safe work practices on the job by your words and examples.
8. Make suggestions to safety committee representative or Coach about changes you believe will improve team safety.

2.3 Resources to Maintain Safety and Health Program

1. Coach shall ensure that sufficient team member time, supervisor support, and funds are budgeted for safety equipment, training and to carry out the safety program.
2. Parents and team members shall support fund raising to provide PPE for team members;
3. Team “Parents” will support safety during travel.
4. Aviation High School will support overall shop safety related to shop equipment, i.e. machine guarding.

2.4 Safety Committee

A safety committee shall be formed for consultation regarding accident investigation and further development of the safety plan.

2.4.1 Safety Committee Members

A safety committee shall be formed consisting of the following members:

1. Coach (Mr. Steele)
2. Safety Mentor (Steve Tarilton)
3. Safety Captain (Hunter McSwain)
4. Members of Pit Crew
5. Another student member shall be selected by Coach or shall be a team volunteer, if necessary. This shall be necessitated by a lack of involvement at various grade levels. Student members of the safety committee shall consist of at minimum, a freshman or sophomore, and a junior or senior.
6. The safety captain and member of the pit crew shall be selected by the Coach, if there are no team volunteers.

2.4.2 Responsibilities

The safety committee shall be responsible for the following:

1. Update policies as necessary for each competition season
2. Maintain safety and health program
3. Maintain policies and procedures
4. Assist in training
5. Assist in acquiring and maintaining PPE
6. Maintenance of Material Safety Data Sheets (MSDS) in shop and for travel

2.4.3 Safety Meetings

1. A Safety Meeting shall be held within three working days of the FRC Kickoff.
2. A Safety Meeting shall be held at the completion of design review.
3. A Safety Meeting shall be held at the midpoint of construction.
4. A Safety Meeting shall be held a week prior to the first competition.
5. A Safety Meeting shall be held at the close of the season.
6. A committee member will be designated at each meeting to keep minutes on the form in Appendix B. A copy will be posted electronically in the team designated electronic file. After being posted until the next meeting, the minutes will be filed for one year. The minutes form contains the basic meeting agenda.

2.5 Disciplinary actions for safety and health infractions

Team members are expected to use good judgment when doing their work and to follow established safety rules. We have established a disciplinary policy to provide appropriate consequences for failure to follow safety rules. This policy is designed not so much to punish as to bring unacceptable behavior to the team member's attention in a way that the team member will be driven to make corrections, and to ensure that no one is harmed by unacceptable behavior. The following consequences apply to the violation of the same rule or the same unacceptable behavior:

2.5.1 Verbal warning infractions

Initial infractions, e.g., not wearing proper safety equipment, shall receive a verbal warning.

Suspension will occur for the following violations:

1. After three verbal warnings, team member shall be suspended for one week.
2. Removing safe guarding from shop equipment.
3. At the discretion of the Coach for safety infractions.
4. Not following chaperone's instructions during travel.
5. Encouraging others to do unsafe acts

2.5.2 Team Member Removal

After two suspensions, a team member shall be removed from the team for that season.

3.0 Team Safety Analysis

An important component of the safety and health program is assessment of potential hazards and ongoing evaluation of the program. This is important to the evolution of the program as members adopt it and it becomes part of the season. Through assessment and improvement it becomes integrated into the team's framework. Skunkworks is committed to aggressively identifying potentially hazardous conditions and practices that are likely to result in injury or illness to team members. We will take prompt action to eliminate any hazards we find. In addition to reviewing injury records and investigating incidents for their causes, the Coach and the safety committee will regularly check the workplace for hazards as described below.

3.1 On-site inspection of shop area

The shop area shall be inspected weekly for safety and health hazards. The job safety analysis form in Appendix B shall be used as a reference for the inspection. Any deficiencies shall be reviewed and mitigated. After the deficiencies are corrected, a new analysis shall be performed to evaluate the effectiveness of the mitigation.

3.1.1 Job Safety Analysis Form for Shop

1. The job safety analysis form shall be completed for each operation in the shop. This shall be completed by the Safety Captain with support from the Safety Mentor.
2. This shall be evaluated at the start of each season.
3. This shall be maintained in electronic format.

3.1.2 Deficiencies Found

1. The deficiencies shall be reviewed by the Safety Committee.
2. A mitigation plan shall be formed and instituted with the Safety Captain taking the lead with support from the Coach and Safety Mentor.
3. A new analysis shall be performed after the mitigation plan is instituted.

3.1.3 Audits by Mentors

1. An audit of the safety and health program and the entire shop area shall be performed at the start of each season by the Safety Mentor or person with expertise in this area. The audit shall be supported by the Coach and Safety Captain for that season. They will document in writing any safety hazards or potential hazards they find. The results of this audit will be used to eliminate or control obvious hazards, and target specific work areas for more intensive investigation.
2. A suggested resource for the auditor is the Washington State Department of Labor and Industries Safety and Health Program Assessment worksheet, which is found in Appendix B.
3. Improvements in the program shall be instituted by the Safety Committee.
4. The improvements shall be evaluated during the build portion of the competition season.

3.2 Competition

During competitions the safety policies and procedures put forth by the *FIRST* Robotics Competition Team Safety Manual (Appendix A) shall be instituted and followed. During competitions the safety checklist in Appendix A of the *FIRST* Robotics Competition Team Safety Manual shall be completed by the Safety Captain or designated team member. The Safety Committee and pit crew shall read and understand the *FIRST* Robotics Competition Team Safety Manual. An acknowledgement form is contained in Appendix B.

3.2.1 Team Travel Safety Protocol

When traveling with the team, students are expected to know and follow the travel safety guidelines set forth by the coach, mentors, and parent volunteers. Students will stay on site with the team unless authorized to leave with their allotted chaperone.

3.3 Accident/incident investigation

All injury producing incidents and “near misses” will be investigated for root cause by the Safety Committee with external support where necessary.

3.3.1 Coach's Action

1. Investigate a serious injury or illness using procedures in the "Incident Investigation" section below.
2. Complete an "Incident Investigation Report" form.
3. Give the “Team’s Report” and the “Incident Investigation Report” to the Safety Mentor and Safety

Captain.

3.3.2 The Safety Committee's Action

1. Make any new injury reports and investigations available to the safety committee for review before the scheduled safety committee meeting.
2. The safety committee will review the log for trends and may decide to conduct a separate investigation of any incident.

3.3.3 Incident Investigation Procedure

1. Only aid in scene by calling for medical assistance.
2. The investigation team will take written statements from witnesses, photograph the incident scene and equipment involved. The team will also document the condition of equipment and any anything else in the work area that may be relevant as soon as possible after the incident. The team will make a written "Incident Investigation Report" of its findings. The report will include a sequence of events leading up to the incident, conclusions about the incident and any recommendations to prevent a similar incident in the future. The report will be reviewed by the safety committee at its next regularly scheduled meeting.
3. When the Coach becomes aware of an injury that was not serious enough to warrant a team investigation as described above, the Coach will write an "Incident Investigation Report" in accordance with Aviation High School policies.
4. Whenever there is an incident that did not but could have resulted in serious injury to a team member (a near-miss), the incident will be investigated by the Coach or Safety Committee depending on the seriousness of the injury that would have occurred. The "Incident Investigation Report" form will be used to investigate the near-miss. The form will be clearly marked to indicate that it was a near miss and that no actual injury occurred.
5. An "Incident Investigation Report" form can be found in the Appendix to help the Coach carry out his/her responsibilities as described above.

4.0 Hazard Prevention and Control

This section includes specific requirements to identify and prevent any potential hazards from causing harm to our team. The below listed rules have been established to help make our work environment a safe and efficient place to build a robot. These rules are comprised of the general safety rules (Section 4.01) and the job specific safety rules (Section 4.02). We have established safety rules and personal protective equipment (PPE) requirements based upon a hazard assessment for each task listed below. Failure to comply with these rules will result in disciplinary action.

Skunkworks is committed to eliminating or controlling hazards that could cause injury or illness to our team members. Whenever possible we will design the workplace and robot to eliminate team members' exposure to hazards while building the robot and during use of the robot. Where these engineering controls are not possible, we will write work rules that effectively prevent team exposure to the hazard. When the above methods of control are not possible or are not fully effective, we will require team members to use personal protective equipment (PPE) such as safety glasses, hearing protection, foot protection, etc.

4.1 General Safety Rules

4.1.1 Basic Safety Rules

1. Never do anything that is unsafe in order to get the robot built. If a job is unsafe, report it to your safety captain or mentor. A safer way can be found to do the job.
2. Do not remove or disable any safety device! Keep guards in place at all times on operating machinery.
3. Never operate a piece of equipment in the shop unless you are working with a mentor or have been trained and are certified to use that tool.
4. Use your personal protective equipment whenever it is required.
5. Obey all safety warning signs.
6. Being under the influence of alcohol or illegal drugs or using them as part of this team is prohibited.
7. Horseplay, running and fighting are prohibited
8. Clean up spills immediately
9. No food or drinks in the shop.
10. Put back in the allotted space all tools and supplies after use.
11. Do not allow scraps to accumulate where they will become a hazard. Good housekeeping helps prevent injuries.

4.1.2 Basic Machine Shop Safety Rules

1. Never operate a piece of equipment in the machine shop unless you are working with a mentor or have been trained and are certified by the safety mentor or Coach.
2. Turn on ventilation equipment prior to using shop equipment (e.g., table saw, etc.).
3. Do not reach around or behind any operating piece of equipment.
4. Do not overreach when operating machinery. Keep proper footing and balance at all times.
5. Do not force any piece of equipment. The equipment cuts better and more safely at the rate for which it was designed.
6. Keep your hands out of the path of the cutting surface.
7. Allow motor to reach full speed before beginning operations (e.g., cutting or grinding, etc.).
8. Do not touch the equipment until it has stopped completely. Turn the power off.
9. Keep the floor around the equipment clean and free of obstructions or clutter.
10. No open toe or open heel shoes.
11. No loose clothing.
12. Before beginning work on a piece of equipment, always check it for correct setup and always check to see if the equipment is clear by operating it manually, if possible.
13. Think through the entire job before starting; ask for help if you have questions.
14. Do not work in the shop if you are tired or in a hurry – this almost always causes accidents.

15. No loose jewelry.
16. Confine long hair.
17. Clamp down your work with c-clamps or a vice depending on what you are working on.

4.2 Required PPE for Machine Shop

4.2.1 Safety glasses

1. Check for broken or missing components (such as side shields) and for scratched lenses prior to use. Safety glasses must have a "Z87.1" marking on the frame.
2. For personnel who wear prescription eye glasses, use safety glasses that fit over prescription eye glasses or use a face shield with your glasses. Never use a face shield without safety glasses beneath it.

4.2.2 Hearing protection

1. Use ear plugs or ear muffs when operating the following equipment: table saw, chop saw and band saw, and grinder.
2. The effectiveness of hearing protection is reduced greatly if the hearing protectors do not fit properly or if they are worn only part time during periods of noise exposure. To maintain their effectiveness, they should not be modified.

4.2.3 Foot protection

1. Wear only closed toe and closed heel shoes in the shop and during the competition.
2. Flip-flops, sandals, mules, crocs, clogs, etc are not allowed in machine shop or in the pit.

4.2.4 Hand protection

1. Use hand protection designed to protect against specific hazards:
 - a) When handling batteries for robot, use acid resistant gloves, such as nitrile.
 - b) When using sharp hand tools or handling sharp machined parts, use leather or thick canvas or other similar type gloves.
2. Check your gloves for proper size, absence of cracks and holes, and good flexibility and grip.

4.3 Job Related Safety Rules

4.3.1 Work in or passing through the Machine shop

1. Do not distract or talk with team members when they are using a machine in the shop.
2. Walk within marked aisles.
3. No more than two people operating a lathe or drill press at a time. Others watching may do so from behind designated lines.

4.3.2 Work with grinders: Machine shop

1. Required PPE:
 - a) As previously stated.
 - b) In addition, a face shield must be worn when operating the grinder.
2. Work Rules:

- a) Check that the gap between the tool rest and the wheel is less than 1/8".
- b) Check that the upper wheel (tongue) guard gap is less than 1/4".
- c) Check that the wheel edge is not excessively grooved. Dress the wheel if necessary.
- d) Do not grind on the face of the wheel. Run a new grinding wheel for about one minute before engaging the wheel.
- e) Stand to one side of the wheel before starting the grinder.

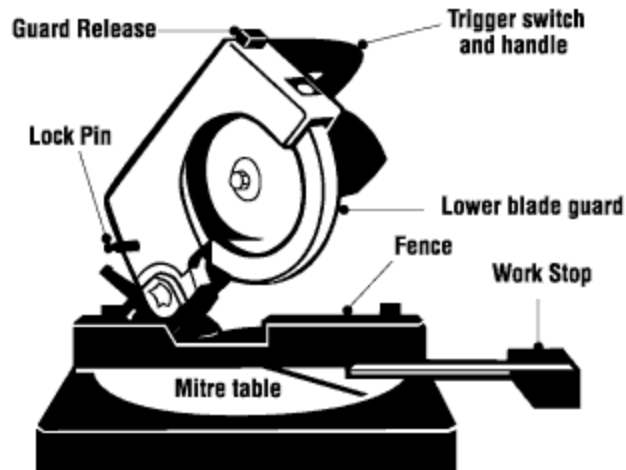

MITER SAW¹

4.3.3 Work with Miter Saws: Machine shop

1. Keep one hand on the trigger switch and handle and use the other hand to hold the stock against the fence.
2. Keep hands out of the path of the blade.
3. Keep guards in place and ensure that they are in working order.
4. Remove adjusting keys and wrenches before and after operation.
5. Use only a crosscut or combination blade.
6. Ensure that the blade rotates in the correct direction.
7. Ensure that the blade and arbor collars are secure and clean. Recessed sides of collars should be against blade.
8. Keep blade tight, clean, sharp and properly set so that it cuts freely and easily.
9. Do not cut pieces smaller than 20 cm (8 in.) in length.
10. Do not cut "free hand." The stock should lie solidly on the table against the fence.

¹ Photo provided by www.ccohs.ca/oshanswers/safety_haz/

11. Do not take your hand away from the trigger switch and handle until the blade is fully covered by the lower blade guard.

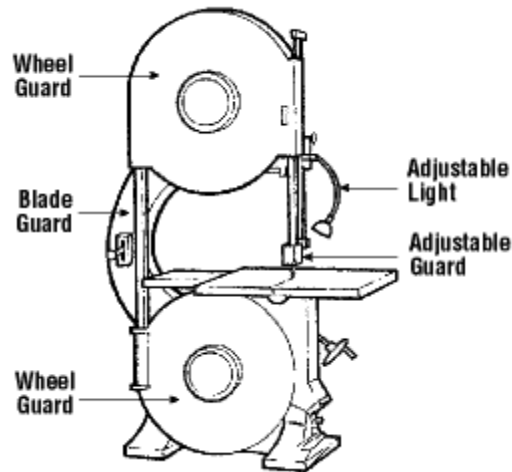

1

BAND SAW

4.3.4 Work with Band Saw: Machine shop

1. Make sure all guards are in place and properly adjusted. Ensure all band wheels are enclosed.
2. Adjust blade guard height to about 3 mm or 1/8 inch above the top of the material being cut.
3. Ensure the blade is tracking correctly and runs freely in and against the upper and lower guide rollers.
4. Ensure the blade is under proper tension. A band saw equipped with automatic tension control is desirable.
5. Use band saw blades that are sharp, properly set and otherwise suitable for the job (e.g., the right tooth pitch; tooth form; blade width).
6. Hold stock firmly and flat on the table to prevent the stock from turning and drawing your fingers against the blade. Keep hands braced against the table.
7. Use a push stick when you remove cut pieces from between the fence and saw blade or when your hands are close to the blade. Keep your hands on either side of the blade - not in line with the cutting line and the blade.
8. Make release (relief) cuts before tight curves when doing intricate scroll-type work.
9. Keep the machine properly oiled and serviced.
10. Do not use excessive force when pushing the wood past the blade.
11. Do not back the stock away from the blade while the saw is in motion if the work piece binds or pinches on the blade.
12. Do not stop a band saw by thrusting stock against the cutting edge or the side of a blade immediately after the power has been shut off.
13. Do not remove sawdust or cuttings from the table by hand or with compressed air. Use a stick or

1 Photo provided by www.ccohs.ca/oshanswers/safety_haz/

brush.

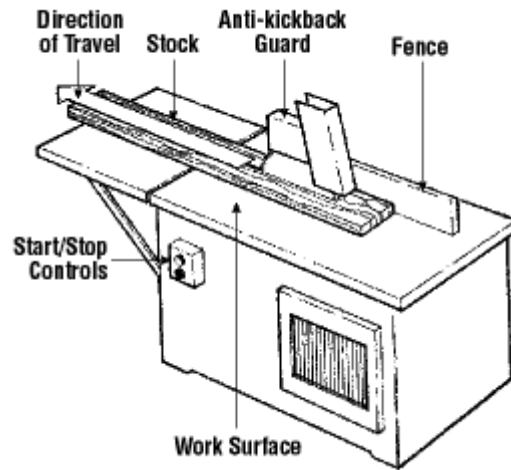

TABLE SAW

4.3.5 Work with Table Saw: Machine shop

1. Table saws are only to be operated by mentors.
2. Pay particular attention to reducing the risk of kickback (when the stock or work piece can be violently thrown back toward the operator).
3. Choose proper blades for the type of work being done.
4. Keep blades clean, sharp, and properly set so that they will cut freely without having to force the work piece against the blade.
5. Use the guards provided with the saw or ones designed for use with the saw that you are using. Keep them in place and in good working condition.
6. Use a guard high enough to cover the part of the blade raising above the stock and wide enough to cover the blade when it is tilted. The blade height should be set so it does not extend more than about 3 mm (1/8 in) above the height of the piece being cut.
7. Ensure that the fence is locked in position after the desired width has been set.
8. Hold the work piece firmly down on the table and against the fence when pushing the work piece/stock/metal through.
9. Ensure that there is adequate support to hold a work piece; use extension tables or roller supports at the side or back for larger pieces.
10. Feed stock into the blade against the direction of its rotation.
11. Move the rip fence out of the way when cross cutting. Never use it as a cut off gauge.
12. Use a push stick when ripping narrow or short stock (e.g., when the fence is set less than about 15 cm (6 in) from the blade; when the piece is less than 30 cm (12 in) long or when the last 30 cm (12 in) of a longer piece is being cut).

1 Photo provided by www.ccohs.ca/oshanswers/safety_haz/

13. Use guard with a spreader (riving knife) and anti-kickback fingers for all ripping or cross cutting operations.
14. Keep the body and face to one side of the saw blade out of the line of a possible kickback.
15. When shutting off the power, never attempt to stop the saw quickly by shoving anything against the blade. Make sure the saw has stopped before leaving it.
16. Provide adequate support to the rear and sides of a saw table for wide or long stock.
17. Be careful when waxing, cleaning, or servicing the table. Shut off and unplug (or lock out) a saw before doing any work on the saw.

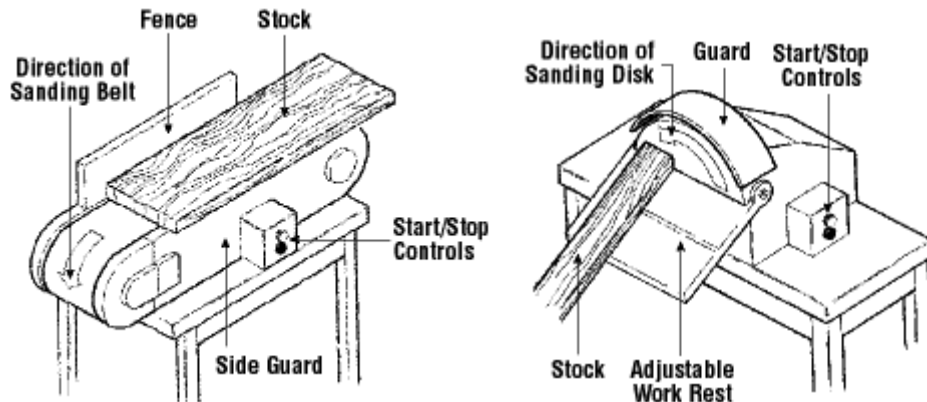

HORIZONTAL BELT SANDER¹ DISC SANDER²

4.3.6 Work with Belt Sander: Machine shop

1. Hold small or thin pieces of stock in a jig or holding device to prevent injuries to the fingers or hands.
2. Inspect abrasive belts before using them. Replace belts worn, frayed, or excessively worn in spots.
3. Sand on the downward side of a disc sander or belt so that the material is driven onto the table by the machine's rotation.
4. Adjust work rests on all manually fed sanders to provide minimum clearance between the belt and the rest. The work rest should be secured properly.
5. Install abrasive belts that are the same width as the pulley drum.
6. Adjust abrasive belt tension to keep the belt running the same speed as pulley-drum when the wood is in contact with the belt.
7. Guard feed rollers to allow boards to pass, but keep operators' fingers and arms out.

4.3.7 Work with Drill Press: Machine shop

1. Use a vacuum, brush or rake to remove cuttings.
2. Remove burrs and chips from a drilled hole. When making deep holes, clean out the hole frequently.

1 Photo provided by www.ccohs.ca/oshanswers/safety_haz/

2 Photo provided by www.ccohs.ca/oshanswers/safety_haz/

3. Use a clamp or drill vise to prevent work from spinning.
4. Don't use a dull or cracked drill. Inspect the drill before using.
5. Lubricate drill bit when drilling metal.
6. Reduce the drilling pressure when the drill begins to break through the work piece. This action prevents drill from pulling into the work and breaking.
7. Keep drill bits clean and sharp. Dull drills are a common cause of breakage.
8. Roll sleeves above the elbow to prevent them from being caught in revolving parts.
9. Do not wear gloves, rings, watches, or bracelets while working with a drill press.
10. Do not set speeds, adjust, or measure work until machine is completely stopped.
11. Do not leave chuck key in drill chuck. Make adjustments and remove key immediately.
12. Do not hold work by hand when drilling holes larger than 12 mm (1/2 in.) in diameter.
13. Always try to support the part on parallels or a backing board when drilling thru material.
14. When drilling a deep hole withdraw the drill bit frequently to clear chips and lubricate the bit.
15. If the drill binds in a hole, stop the machine and turn the spindle backwards by to release the bit.
16. Do not place hands under the stock being drilled.
17. Do not stop rotation of chuck and spindle with your hand.
18. Do not remove a broken drill with a centre punch and hammer.

4.3.8 Work with Lathe: Machine shop

1. Use a vacuum, brush or rake to remove cuttings.
2. Center drill work deeply enough to provide support for the piece while it is turning.
3. Adjust tool and tool rest so that they are slightly above the center of the work.
4. Make sure that the chuck, driveplate, or, faceplate is securely tightened on the lathe spindle.
5. When installing or removing the chuck, driveplate, or faceplate do not use machine power.
6. Move the tool bit a safe distance from the collet or chuck when inserting or removing work.
7. Do not run the machine faster than the proper cutting speed – consult a speed and feed table to determine the best speed.
8. Inspect chucks for wear or damage. Flying pieces can be very dangerous.
9. Remove chuck wrench immediately after adjusting chuck.
10. Always clamp the tool bit as short as possible in the tool holder to prevent it from breaking or chattering.
11. Always make sure that the tool bit is sharp and has the proper clearance.
12. If any filing is done on work revolving in the lathe, file left handed to prevent slipping into the chick. Never use a file without a handle.
13. Set the tool bit on the centerline of your work to prevent work form climbing over tool or cutting above center and dragging.

14. Use a barrier guard when operating the lathe in semi-automatic or automatic mode.
15. Guard all power transmission parts.
16. Remove all tools, measuring instruments and other objects from saddle or lathe bed before starting machine.
17. Ensure that the chip and coolant shields are in place.
18. Shut off the power supply to the motor before mounting or removing accessories.
19. Stop lathe before taking measurements of any kind.
20. Use a vacuum, brush or rake to remove cuttings only after the lathe has stopped moving.
21. Do not lean on machine. Stand erect; keep your face and eyes away from flying chips.
22. Do not place hands on work turning in the lathe.
23. Do not use calipers or gauges on a work piece while machine is moving.
24. Do not make heavy cuts on long slender pieces because the work could bend and fly out of the lathe.

4.3.9 Work with Milling Machine: Machine shop

1. Ensure that the work piece and cutter are mounted securely before taking a cut.
2. Check that work is mounted squarely.
3. Mount work in a vice that is bolted or held magnetically to the table. Use proper hand tools to make adjustments. Refer to Hand Tools for more information.
4. Hold milling cutters with a cloth to avoid being cut when handling them.
5. Move table as far as possible from cutter while setting up work to avoid injuring your hands.
6. Mill the largest surface first.
7. Keep hands, brushes and rags away from the revolving milling cutter.
8. Use a vacuum, brush or rake to remove cuttings only after the cutters have stopped moving.
9. Change cutting compounds periodically.
10. Keep cutters sharpened correctly and in good condition.
11. Keep working surface clear of scraps, tools and materials.
12. Keep floor around the milling machine free of oil and grease.
13. Ensure that the following factors are considered when setting cutting speed:
 - a) Material to be machined
 - b) Type of cutter
 - c) Finish required
 - d) Depth of cut
 - e) Rigidity of machine and work piece
14. Do not attempt to mount measure or adjust work until cutter is completely stopped.
15. Do not use an excessively heavy cut or feed as it can cause the cutter to break. The flying pieces could cause serious injury.

16. Do not reach over or near a revolving cutter. Keep hands at least 30 cm (12 in.) from a revolving cutter.
17. Do not lean or rest hands on a moving table.
18. Do not make any adjustments while the machine is running.
19. Do not use paper shims to check the distance from the cutter to the stock.
20. Do not move the operating levers without knowing what they control and what action is going to take place. Use a vacuum, brush or rake to remove cuttings.

4.3.10 Work with hand tools

1. Use good quality tools.
2. Keep tools in good condition at all times. Keep them clean and dry, and store them properly after each use.
3. Inspect tools for defects before use. Replace or repair defective tools.
4. Keep cutting tools sharp and cover sharp edges with suitable covering to protect the tool and to prevent injuries from unintended contact. .
5. Replace cracked, splintered, or broken handles on files, hammers, screwdrivers, or sledges.
6. Ensure that the handles of tools like hammers and axes fit tightly into the head of the tool.
7. Replace worn jaws on wrenches, pipe tools and pliers.
8. Redress burred or mushroomed heads of striking tools.
9. Pull on a wrench or pliers. Never push unless you hold the tool with your palm open.
10. Point sharp tools (e.g., saws, chisels, knives) laying on benches away from aisles, and handles should not extend over the edge of the bench top. When using going in a direction away from your body.
11. Use a heavy belt or apron and hang tools at your sides, not behind your back.
12. Do not use tools for jobs they are not intended to do. For example, do not use a slot screw drivers as a chisel, pry bar, wedge or punch or wrenches as hammers.
13. Do not apply excessive force or pressure on tools.
14. Do not cut towards yourself when using cutting tools.
15. Do not hold the stock in the palm of your hand when using a cutting tool or a screwdriver.
16. Do not wear bulky gloves to operate hand tools.
17. Do not throw tools. Hand them, handle first, directly to other team members.
18. Do not carry a sharp tool in your pocket.

4.3.11 Work with power hand tools

1. Follow above rules as appropriate.
2. Do not carry by the cord or hose.
3. Do not yank the cord or hose to disconnect from receptacle.
4. Do not place cord or hose near heat, oil or sharp edges.
5. Do not leave tools connected when not in use.

4.4 Chemical Safety

4.4.1 Work Rules

1. Learn about the chemicals that you are planning to use before opening them. Read the instructions and Material Safety Data Sheets (MSDS).
2. MSDS for chemicals used in the machine shop are posted on the flammable storage cabinet.
3. New chemicals shall not be used in the machine shop without first informing the Coach and Safety Captain and providing an MSDS.
4. New MSDS shall be posted at flammable storage cabinet.
5. Chemicals shall be stored in flammable storage cabinet. Store incompatible materials away from one another.
6. First Aid kit is adjacent to the door when you walk in the shop. It is the responsibility of the safety captain to make sure the kit is complete and up to date.
7. Spill kit is located in the machine shop next to the first aid kit. It is the responsibility of the safety captain to make sure the kit is complete and up to date.
8. Follow policies and procedures listed in FIRST Robotics Competition Team Safety Manual on pages 7-10.

4.4.2 Required PPE

1. For battery handling, use acid resistant gloves, such as nitrile.
2. For handling other chemicals, use appropriate PPE as directed on MSDS.

4.5 Competition Safety Rules

4.5.1 Required PPE

1. As listed in FIRST Robotics Competition Team Safety Manual but at a minimum when working in the pits as follows:
 - a) Hand protection
 - b) Eye protection
 - c) As directed by Safety Captain or Coach or Safety Mentor

4.5.2 Work Rules

1. All policies and procedures in FIRST Robotics Competition Team Safety Manual shall be followed.
2. When working in the pits ensure that the safety and stored energy procedures of the FIRST Robotics Competition Team Safety Manual are followed.

4.6 Emergency Planning

4.6.1 In Case of Fire

1. Follow Aviation High School rules when on campus.
2. Follow rules as provided by competition event provider, e.g., Tacoma Convention Center rules.

4.6.2 In Case of Earthquake

1. Follow Aviation High School rules when on campus.
2. Follow rules as provided by competition event provider, e.g., Tacoma Convention Center rules.

5.0 Safety and Health Training and Education

Training is an essential part of our plan to provide a safe work environment as part of Skunkworks. Team members will learn about this program, learn about hazards, and learn how to protect themselves and co-team members. Also, as part of FIRST we are obligated to share our common safety knowledge with other teams through insight at competitions and through mentoring new teams. To insure that all team members are trained before they start a task that requires training, we have the Safety Captain verify this each season in conjunction with the Coach and Safety Mentor.

5.1 General Safety Training

5.1.1 Basic Safety Orientation Training

1. All team members must attend – if they do not participate they cannot be part of the team.
2. Trainers – Coach, Safety Mentor and Safety Captain
3. Course outline – 60 minutes
 - a) Safety and Health Program Overview
 - b) Personal Protective Equipment Overview
 - c) Safety Committee Overview
 - d) General Safety Overview
4. Required Materials
 - a) MS PowerPoint Presentation entitled “2011-2012 Shop Safety Presentation”
 - b) Safety Roster in Appendix B
5. Shop machinery certification

5.1.2 Competition Safety Orientation Training

1. The entire pit crew must attend – if they do not participate they will not be part of the pit crew
2. Trainers – Coach and Safety Captain
3. Course outline – 30 minutes
 - a) FIRST Robotics Competition Team Safety Manual Overview
 - b) Personal Protection Equipment Overview

4. Required Materials

- a) MS PowerPoint Presentation entitled “Competition Safety Orientation Training”
- b) Safety Roster in Appendix B.

5.1.3 Travel Safety Orientation Training

1. All team members who travel must attend – if they do not participate they will not be allowed to travel with the team.
2. Trainer – Team Parent and Coach
3. Course outline – 30 Minutes
4. Required Materials
 - a) Travel policy
 - b) Safety Roster in Appendix B.

5.2 Personal Protective Equipment Training

The following sections provide cohesive outlines for the presentations on the use of personal protective equipment (PPE).

5.2.1 Eye Protection Training

1. All team members must attend – if they do not participate they will not be allowed to work in the machine shop or in the pits.
2. Trainers – Safety Mentor and Safety Captain
3. Course outline – 30 minutes
 - a) The scope of the eye injury problem
 - b) What contributes to eye injuries at machine shop?
 - c) What causes eye injuries at machine shop?
 - d) Where do injuries happen most often?
 - e) How can eye injuries be prevented
4. Required Materials
 - a) MS PowerPoint Presentation entitled “Eye Protection”
 - b) Eye Protection Video
 - c) Safety glasses and safety shield
 - d) Safety Roster in Appendix B

5.2.2 Hearing Protection Training

1. All team members must attend – if they do not participate they will not be allowed to work in the machine shop.
2. Trainers – Coach, Safety Mentor and Safety Captain
3. Course outline – 30 minutes

- a) The effects of noise on hearing,
 - b) Hearing protection – purpose, types and use
4. Required Materials
- a) MS PowerPoint Presentation entitled “Hearing Protection”
 - b) Hearing Protection Video
 - c) Ear plugs and muffs
 - d) Safety Roster in Appendix B

5.2.3 Hand Protection Training

1. All team members must attend – if they do not participate they will not be allowed to work in the pits or machine shop.
2. Trainers – Safety Mentor and Safety Captain
3. Course outline – 30 minutes
 - a) Hand Hazards
 - b) Types of Gloves
 - c) Limitations
 - d) Use and Care
 - e) Chemical-resistant gloves
4. Required Materials
 - a) MS PowerPoint Presentation entitled “Hand Protection”
 - b) Examples of various hand protection
 - c) Safety Roster in Appendix B

5.3 Structured Specific Safety Training

5.3.1 Machine Shop Safety Training

1. - All team members must attend– if they do not participate they will not be part of the team.
2. Trainers – Coach, Safety Mentor and Safety Captain
3. Course outline – 60 minutes
 - a) Safety and Health Program Overview
 - b) Work Rules Overview
 - c) Machine Guarding Overview
 - d) Ventilation Overview
4. Required Materials
 - a) MS PowerPoint Presentation entitled “Machine Shop Safety Training”
 - b) Tour of machine shop

c) Safety Roster in Appendix B.

5.3.2 Chemical Safety Training Overview

1. All team members must attend– if they do not participate they will not be part of the team.
2. Trainers – Safety Mentor and Safety Captain
3. Course outline – 30 minutes
 - a) What is an MSDS
 - b) Work Rules Overview
 - c) How to use a spill kit
 - d) Basic Chemical Safety Overview
4. Required Materials
 - a) MS PowerPoint Presentation entitled “Chemical Safety Training”
 - b) Safety Roster in Appendix B.

6.0 Appendices

6.1 Appendix A

First Robotics Competition

6.2 Appendix B

Skunkworks Incident Investigation Form

Skunkworks Job Hazard Analysis Form Skunkworks

Acknowledgement Form Skunkworks Safety And Health Program

Skunkworks Job Hazard Analysis Form

Skunkworks Safety Training Roster

6.3 Appendix C

2010 Safety Presentation

Skunkworks Eye Protection Training Presentation

Skunkworks Eye Protection Training Certificate

Revision Record Sheet

Document: Safety Plan Skunkworks Robotics

<u>Rev #</u>	<u>Changes</u>	<u>Date</u>
Rev 3	Edited and added to ToC	2/15/2012
Rev 2	Replaced ToC, Formatted Numbering	1/25/11
Rev 1	Worked on new ToC, removed numbers for Appendix	1/24/11
Rev New	Original Document	2008